

Front view and mounting

Side view

Rear view

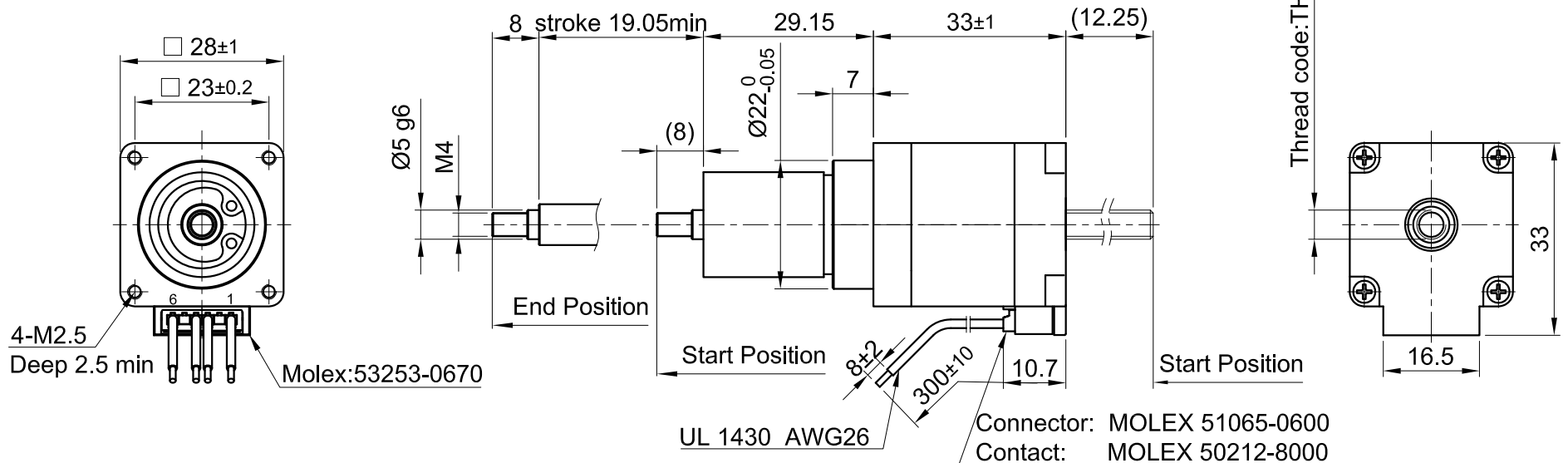

CONNECTION	BIPOLAR
SPECIFICATION	BIPOLAR
AMPS/PHASE	1.0
RESISTANCE/PHASE (Ohms)@25°C	2.7±15%
INDUCTANCE/PHASE (mH) @1KHz	2.5±20%
THREAD DIAMETER (mm) [in]	5 [0.197]
THREAD LEAD(mm) [in]	2 [0.079]
THUST (N) [lbf]	93.4 [21.02]
RESOLUTION (mm/STEP)	0.01
MAX. SPEED (mm/sec.) AT 24V	35
WEIGHT (Kg) [lb]	0.14 [0.31]
TEMPERATURE RISE: MAX.80°C (MOTOR STANDSTILL; FOR 2 PHASE ENERGIZED)	
AMBIENT TEMPERATURE -10°~ 50°C [14°F ~ 122°F]	
INSULATION RESISTANCE 100 MOhm (UNDER NORMAL TEMPERATURE AND HUMIDITY)	
INSULATION CLASS B 130° [266°F]	
DIELECTRIC STRENGTH 500VAC FOR 1 MIN. (BETWEEN THE MOTOR COILS AND THE MOTOR CASE)	
AMBIENT HUMIDITY MAX. 85% (NO CONDENSATION)	

Please regard the application note at [www.nanotec.com](http://www.nanotec.com) for further informations.



TYPE OF CONNECTION (EXTERN)	MOTOR		
BIPOLAR	CONNECTOR PIN NO.	LEADS	WINDING
A —	1	BK	A
A\ —	3	GN	A\
B —	4	RD	B
B\ —	6	BU	B\

WIRING DIAGRAM

FULL STEP 2 PHASE-Ex., WHEN FACING MOUNTING END (X)

STEP	A	B	A\	B\	CCW	CW
1	+	+	-	-	↓	↑
2	-	+	+	-	↓	↑
3	-	-	+	+	↓	↑
4	+	-	-	+	↓	↑

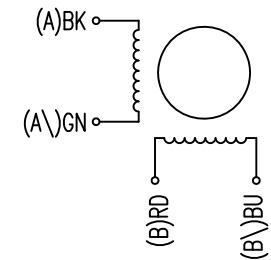

REV	DESCRIPTION	DATE	APVD	 <b>Nanotec</b> <sup>®</sup> PLUG & DRIVE			APVD	P.R.	DATE	<b>LINEAR ACTUATOR</b> DWG.NO LGA281S10-A-THCA-019
1	Remove shaft play adjustable	11.03.19	X T	Surface specification DIN ISO 1302	General tolerances DIN ISO 2768-CH	Work piece edge DIN ISO 13715	CHKD	GYQ	24.07.18	
A	-	31.01.19	X T				DRN	X T	24.07.18	
REV	DESCRIPTION	DATE	APVD				SIGNATURE	DATE		